

Parts List.

- Two mounting brackets
- Two bracket pins
- Two carrier hoops
- Two 12' lengths of cord
- Two 8' lengths of line and one line separator.

Installation on a swim platform:

1. Using the short lengths of cord, tie the pins to the mounting brackets so they are not lost. (Shown in Drawing 1)

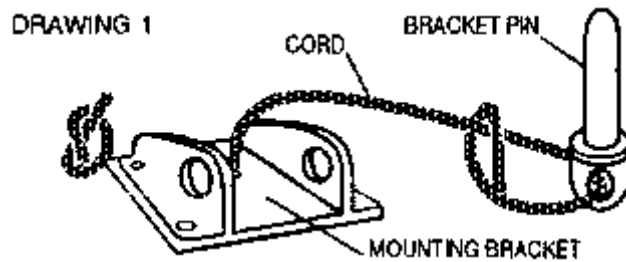

2. Mount the brackets on the edge of the swim platform. Brackets should be as far aft as possible and a minimum of 2' apart. For maximum stability, the brackets should be as far apart as possible. That distance depends on the size of your inflatable. (We recommend that, if possible, you position the carrier hoops on your inflatable to check for a convenient and practical location). Place the edge of the bracket flush with the edge of the platform with the 1/2" hole to the aft of the platform. See Drawing 2.

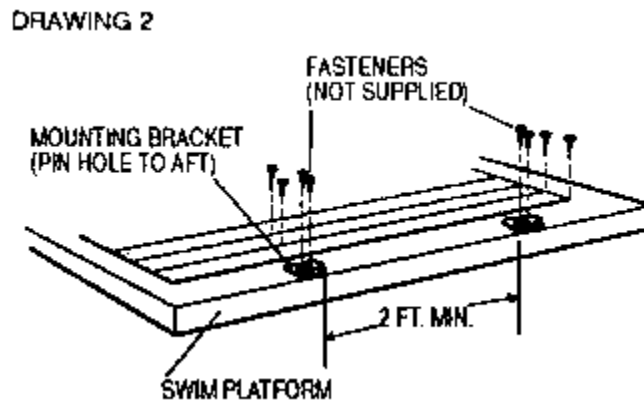

Mark the locations of the holes in the brackets and drill holes for the fasteners of your choice. (Use #10 1" long pan-head wood screws or #10 pan-head bolts and nuts. Not Supplied) Secure the mounting brackets with screws or bolts.

3. Insert the carrier hoops into the brackets and secure with the pins. The short side of the hoops points toward the water.

4. Insert each of the lines through the holes in the lower arm of the

carrier hoops and knot the ends of the lines to secure them.
5. Weave the separator onto the lines. Separator should be located in the center of your inflatable when secured.

Installation on a transom:

1. Using the short lengths of cord, tie the pins to the mounting brackets so they are not lost. (Shown in Drawing 1)
2. Brackets should be a minimum of 2' apart. For maximum stability, the brackets should be as far apart as possible. That distance depends on the size of your inflatable. (We recommend that, if possible, you position the carrier hoops on your inflatable to check for a convenient and practical placement location.) Place the bracket, with the 1/2" hole up, no more than 10" above the water line. See Drawing 3.

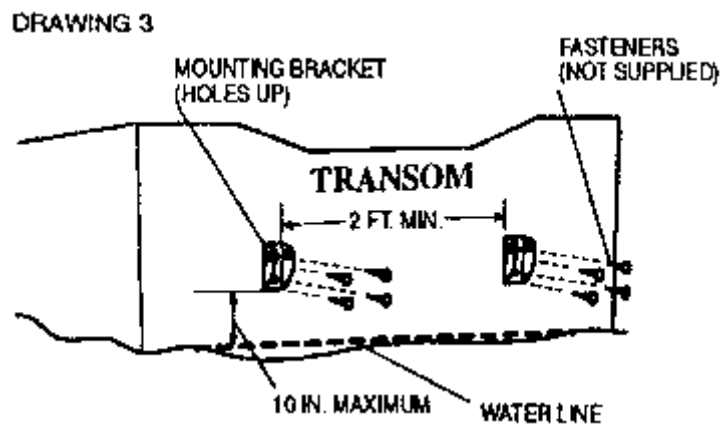

Mark the locations of the holes in the bracket and drill holes for the fasteners of your choice. (Use #10 1" long pan-head wood screws or #10 pan-head bolts and nuts. Not supplied). Secure the mounting brackets with screws or bolts.

3. Insert the carrier hoops into the brackets and secure with pins. The long side of the hoop points toward the water.
4. Insert each of the lines through the holes in the lower arm of the carrier hoops and knot the ends of the lines to secure them.
5. Weave the separator onto the lines. Separator should be located in the center of your inflatable when secured.

Operating Instructions:

1. Float your inflatable alongside the stern of your boat so that the hoops fit around the sides of your inflatable.
2. Remove the motor and any loose items from the boat.
3. Run the lines under the inflatable and from inside the cockpit of your boat, pull the lines so that the inflatable pivots up and out of the water.
4. Pull the lines under the inflatable and secure them around the aft cleats.

To put the inflatable back in the water, reverse the above procedures. When not being used, the carrier hoops may be removed by pulling the bracket pins and stowing the hoops and line.

Lifetime Warranty

ALL EZ LIFTS products are carefully inspected before leaving the factory. PI warrant its products to be free of defects in workmanship or materials. If the product fails in normal use as a result of defects in workmanship or materials, please return it, along with proof of purchase, to the factory for inspection. If we determine the failure was caused by a defect in workmanship or materials, the product will be replaced or, at our option, repaired free of charge. **Defective part must be returned directly to PI for inspection. Customer is responsible for all shipping charges.**

This Lifetime Warranty covers only repairs or replacement of products which are found to be defective in workmanship or materials. It specifically does not cover "complete user satisfaction", and is specifically void if the product has been abused, misused, altered or has been intentionally or accidentally damaged in any manner thought circumstances due to purchaser's misuse, abuse or negligence.